

SBO Series Diaphragm Accumulators



Description

HYDAC diaphragm accumulators utilize the compressibility of a gas (*nitrogen*) in storing hydraulic energy. The gas is required because fluids are practically incompressible and thus, can not store energy by themselves. The diaphragm is utilized to separate the gas and the fluid sides of the accumulator.

The diaphragm accumulator functions by drawing in fluid from the hydraulic circuit when the pressure increases and thus, compresses the gas. It returns this energy to the circuit as the pressure decreases by the expansion of the gas.

A poppet is incorporated into the diaphragm to prevent its extrusion through the fluid port.

HYDAC manufactures two types of diaphragm accumulators:

- welded (non-repairable)
- threaded (repairable)

These have been successfully applied to both industrial and mobile applications for energy storage, maintaining pressure, leakage compensation, and vehicle hydraulic systems (e.g. *brake and suspension*).

Construction

Both types of diaphragm accumulators have the same basic construction. The difference is in the shell. The welded version has a shell that is electron-beam welded, and therefore cannot be repaired. The threaded type has a shell made up of two halves (*top and bottom*) which are held together by a threaded locking ring.

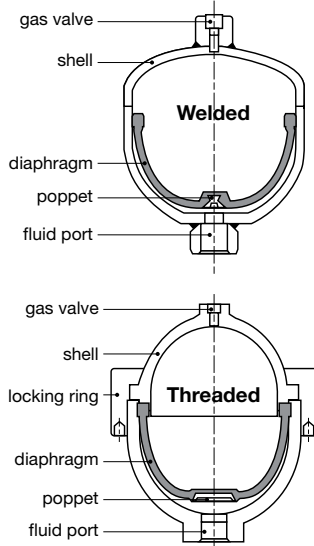

Diaphragm Materials

Not all fluids are compatible with every elastomer at all temperatures. Therefore, HYDAC offers the following choice of elastomers:

- NBR (*Standard Nitrile*)
- LT-NBR (*Low Temperature Nitrile*)
- ECO (*Epichlorohydrin*)
- IIR (*Butyl*)
- FPM (*Fluorelastomer*)
- others (*available upon request*)

To determine which material is appropriate...

ALWAYS REFER TO FLUID MANUFACTURER'S RECOMMENDATION

Corrosion Protection

For use with certain aggressive or corrosive fluids, or in a corrosive environment, HYDAC offers protective coatings and corrosive resistant materials (*i.e. stainless steel*) for the accumulator parts that come in contact with the fluid, or are exposed to the hostile environment.

Mounting Position

Diaphragm accumulators by design may be mounted in any position. In systems where contamination is a problem, we recommend a vertical mount with fluid port oriented downward.

System Mounting

HYDAC diaphragm accumulators are designed to be screwed directly onto the system. We also recommend the use of our mounting components, which are detailed on page 33, to minimize risk of failure due to system vibrations.

Applications

Some common applications of diaphragm accumulators are:

- Agricultural Machinery & Equipment
- Forestry Equipment
- Machine Tools
- Mining Machinery & Equipment
- Mobile & Construction Equipment
- Off- Road Equipment

For specific examples of applications using diaphragm accumulators, please see page 50.

Diaphragm Accumulators **HYDAC**

Model Code

SBO 210 - 1 E4 / 112 S - 210 CK 010

Series

SBO XXX = Diaphragm Accumulator (XXX = series designation)
(see tables on following pages for most common series and size selections)

Size (in Liters, see tables on dimension pages to follow)

0.075 = 0.075 Liters
...see tables on following pages for complete list of sizes, and which versions they are available in
3.5 = 3.5 Liters

Shell Construction and Gas Port Design

E1 = Welded Construction, rechargeable, HYDAC Gas Valve Version 1 (M 28 x 1.5)
E2 = Welded Construction, factory precharged and sealed, (not rechargeable)
E4 = Welded Construction, rechargeable, HYDAC Gas Valve Version 4 (8VI-ISO 4570)
A6 = Threaded Construction, rechargeable, HYDAC Gas Valve Version 1 (M 28 x 1.5)

Material Code

Depending on Application

112 = Standard for oil service (mineral oil)

Fluid Port

1 = Carbon steel
3 = Stainless steel
4 = Chemically plated carbon steel (ONLY WETTED SURFACES for water service)
6 = Low temperature carbon steel (< -20°F)

Shell

0 = Synthetic coated carbon steel (internal & external for water service)
1 = Carbon steel
2 = Chemically plated carbon steel (internal & external for water service)
4 = Stainless steel (please note: MAWP decreases for most stainless models - see tables)
6 = Low temperature carbon steel (< -20°F)

Diaphragm Compound

2 = NBR (Buna N)
3 = ECO (Hydrin)
4 = IIR (Butyl)
6 = FPM (fluoro-elastomer)
7 = Others (available on request)

Compound	Oper. Temp Range	Typical Fluids
NBR	5° to 180°F	mineral oils
	32° to 180°F	water & water-glycols
NBR	-50° to 180°F	mineral oils
ECO...113...	-20° to 250°F	mineral oils
ECO...663...	-40° to 200°F	mineral oils (with low temperature CS shell)
IIR	-20° to 200°F	phosphate esters & brake fluids
FPM	5° to 300°F	chlorinated hydrocarbons

Country of Installation

S = USA
(for other countries see page 2 for proper code designation)

Maximum Working Pressure in bar (see tables on dimension pages to follow)

100 = 1500 psi
140 = 2000 psi
200 = 3000 psi
210 = 3000 psi
250 = 3600 psi
330 = 4700 psi
400 = 5800 psi
450 = 6500 psi
500 = 7200 psi
750 = 10000 psi

Fluid Port Connection

AK = BSP connection
AB = Male / Female combination connection
CK = Standard SAE connection
(other fluid ports available upon request — consult factory)

Gas Precharge Pressure (P_g) in bar (always required for E2 model gas valve)

= 3 digits

Model Codes containing **RED** selections are non-standard items – Contact **HYDAC** for information and availability
Not all combinations are available

HYDAC Diaphragm Accumulators

SBO Series

Non-Repairable Welded Diaphragm Accumulators

Version E1

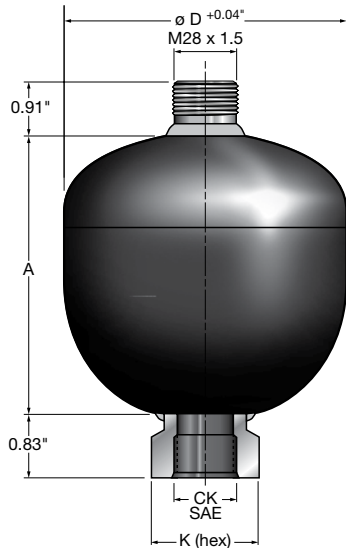

Version E2

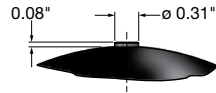

Not available on SBO330 or on any accumulator larger than 1.4 liters.

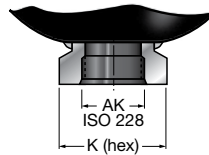

Version E4

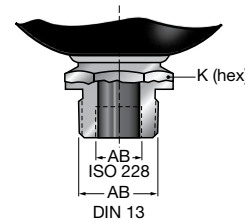
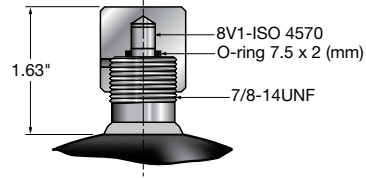

Series	Max. $p_2:p_0$	Size (liters)	Effective Gas Vol in ³	MAWP psi/(bar)	Weight	A	$\varnothing D^2$	F Thread				K (hex)	Q gpm
								CK (SAE)	AK (ISO 228)	AB (ISO 228)	AB (DIN 13)		
SBO 250	8 : 1	0.075	5	3600 (250)	1.5 (0.7)	2.68 (68)	2.52 (64)	9/16-18 UNF	G 1/2	N/A	N/A	1.18 (30)	10
SBO 210	8 : 1	0.16	10	2600/(180) ¹⁾ 3000/(210)	1.8 (0.8)	3.15 (80)	2.91 (74)	9/16-18 UNF	G 1/2	N/A	N/A	1.18 (30)	10
SBO 210	8 : 1	0.32	20	2400/(160) ¹⁾ 3000/(210)	2.9 (1.3)	3.66 (93)	3.66 (93)	3/4-16 UNF	G 1/2	N/A	N/A	1.42 (36)	25
SBO 210	8 : 1	0.5	30	3000 (210)	3.7 (1.7)	4.35 (124)	4.13 (105)	3/4-16 UNF	G 1/2	N/A	N/A	1.42 (36)	25
SBO 330	8 : 1	0.6	36	4700 (330)	7.3 (3.3)	5.04 (128)	4.53 (115)	3/4-16 UNF	G 1/2	G 1/2	M33 x 1.5	1.42 (36)	25
SBO 210	8 : 1	0.75	45	2000/(140) ¹⁾ 3000/(210)	6.2 (2.8)	4.88 (124)	4.76 (121)	3/4-16 UNF	G 1/2	G 1/2	M33 x 1.5	1.42 (36)	25
SBO 330	8 : 1	0.75	45	4700 (330)	8.9 (4.0)	4.78 (122)	4.96 (126)	3/4-16 UNF	G 1/2	G 1/2	M33 x 1.5	1.42 (36)	25
SBO 200	8 : 1	1	60	3000 (210)	7.9 (3.6)	5.39 (137)	5.35 (136)	3/4-16 UNF	G 1/2	G 1/2	M33 x 1.5	1.42 (36)	25
SBO 140	8 : 1	1.4	85	2000 (140)	8.6 (3.9)	5.91 (150)	5.71 (145)	3/4-16 UNF	G 1/2	G 1/2	M33 x 1.5	1.42 (36)	25
SBO 210	8 : 1	1.4	85	3000 (210)	11.9 (5.4)	6.14 (156)	5.91 (150)	3/4-16 UNF	G 1/2	G 1/2	M33 x 1.5	1.42 (36)	25
SBO 330	8 : 1	1.4	85	4700 (330)	16.6 (7.5)	6.33 (160)	6.1 (155)	3/4-16 UNF	G 1/2	G 1/2	M33 x 1.5	1.42 (36)	25
SBO 100	8 : 1	2	120	1500/(100) ¹⁾ 1500/(100)	8.8 (4.0)	6.57 (167)	6.30 (160)	1 1/16-12 UNF	G 3/4	G 3/4	M45 x 1.5	1.81 (46)	40
SBO 210	8 : 1	2	120	3000 (210)	14.6 (6.6)	6.81 (173)	6.57 (167)	1 1/16-12 UNF	G 3/4	G 3/4	M45 x 1.5	1.81 (46)	40
SBO 330	8 : 1	2	120	4700 (330)	17.7 (8.0)	7.12 (180)	6.77 (172)	1 1/16-12 UNF	G 3/4	G 3/4	M45 x 1.5	1.81 (46)	40
SBO 210	4 : 1	2.8	170	3000 (210)	18.0 (8.2)	8.94 (227)	6.57 (167)	1 1/16-12 UNF	G 3/4	G 3/4	M45 x 1.5	1.81 (46)	40
SBO 250	4 : 1	3.5	230	3000 (210)	24.6 (11.2)	11.14 (283)	6.69 (170)	1 1/16-12 UNF	G 3/4	G 3/4	M45 x 1.5	1.81 (46)	40
SBO 330	4 : 1	3.5	230	4700 (330)	30.6 (13.8)	10.78 (274)	6.77 (172)	1 1/16-12 UNF	G 3/4	G 3/4	M45 x 1.5	1.81 (46)	40

Dimensions are for general information only, all critical dimensions should be verified.

Dimensions are in inches/(mm) and lbs/(kg)

1) Stainless steel version for chemical, water, and oil service

2) Diameter at electron beam weld may be up to +0.150" larger

3) May be supplied with adapter

SBO Series Repairable Threaded Diaphragm Accumulators

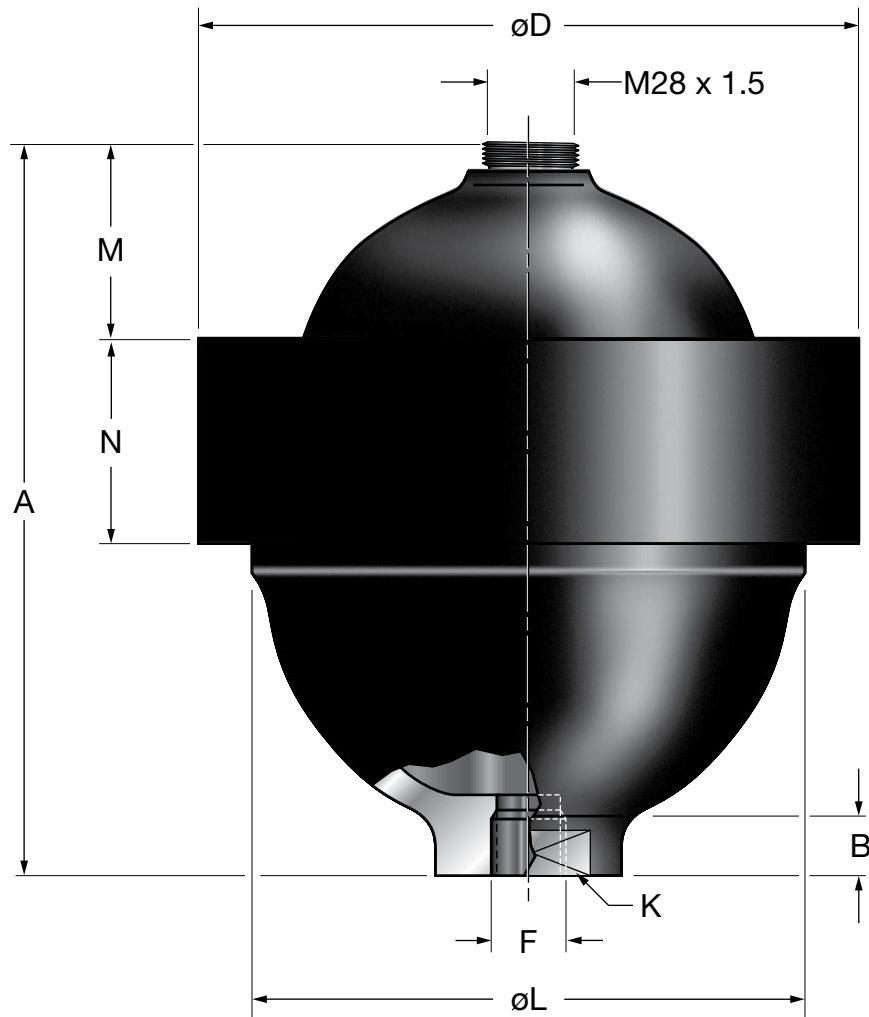

Series	Max. $p_2:p_0$	Size (liters)	Effective Gas Vol in ³	MAWP psi/(bar)	Wt.	A	B	Ø D ¹²	Thread F		K	Ø L	M	N	Q gpm
									SAE	BSPP					
SBO 500	10 : 1	0.1	6	7200 (500)	4.2 (1.9)	4.33 (110)	1.18 (30)	3.74 (95)	3/4-16	G 1/2	1.26 (68)	2.68 (68)	0.87 (22)	1.38 (35)	25
SBO 500	10 : 1	0.25	15	5000/(350) ¹⁾	8.6 (3.9)	5.04 (128)	0.79 (20)	4.53 (115)	3/4-16	G 1/2	1.42 (36)	3.62 (92)	0.71 (18)	2.17 (55)	25
				7200/(500)											
SBO 750	10 : 1	0.25	15	8700/(600) ¹⁾	19.8 (9.0)	5.35 (136)	0.43 (11)	6.02 (153)	3/4-16	G 1/2	1.42 (36)	4.49 (114)	0.59 (15)	2.48 (63)	25
				10000/(750)											
SBO 450	10 : 1	0.6	36	3600/(250) ¹⁾	12.6 (5.7)	6.69 (170)	0.75 (19)	5.51 (140)	3/4-16	G 1/2	1.61 (41)	4.53 (115)	1.77 (45)	2.24 (57)	25
				4700/(330)											
SBO 210	10 : 1	1.3	80	3000 (210)	18.7 (8.5)	7.48 (190)	0.31 (8)	6.69 (170)	3/4-16	G 1/2	1.26 (32)	5.71 (145)	2.24 (57)	2.17 (55)	25
SBO 400	10 : 1	1.3	80	5800 (400)	24.7 (11.2)	7.75 (197)	1.10 (28)	7.91 (201)	3/4-16	G 3/4	1.97 (50)	6.30 (160)	1.97 (50)	2.56 (65)	25
SBO 250	10 : 1	2	120	2600/(180) ¹⁾	25.1 (11.4)	8.93 (227)	0.67 (17)	7.91 (201)	1 1/16-12	G 3/4	1.61 (41)	6.61 (168)	2.44 (62)	2.52 (64)	40
				3600/(250)											

Dimensions are for general information only, all critical dimensions should be verified.
Dimensions are in inches/(mm) and lbs/(kg)

1) Only available in stainless steel construction